

Time-Averaged Ventilation (TAV) Controls for Variable Air Volume Systems

Soazig Kaam, Paul Raftery
CBE

Hwakong Cheng
Taylor Engineering

Gwelen Paliaga
TRC



HVAC Systems

Background

- Zones spend majority of their time at their minimum airflow set-points
- Minimum airflow set-points are typically higher than ventilation requirements
- Current practice causes overcooling and wastes energy
- Perceived and real problems about operating at low airflow

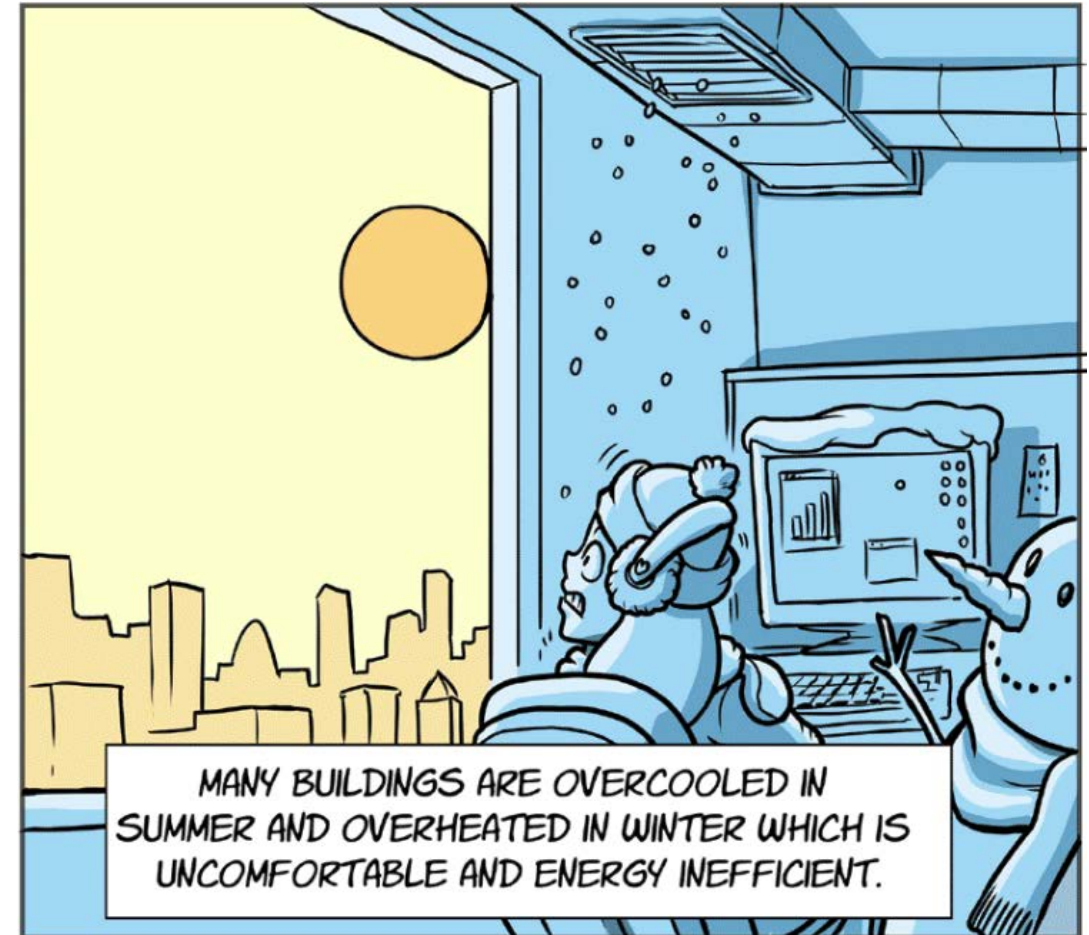

Source: tandfonline.com

Time-averaged ventilation principle

TAV controls the average airflow of a zone to the minimum ventilation rate required by code

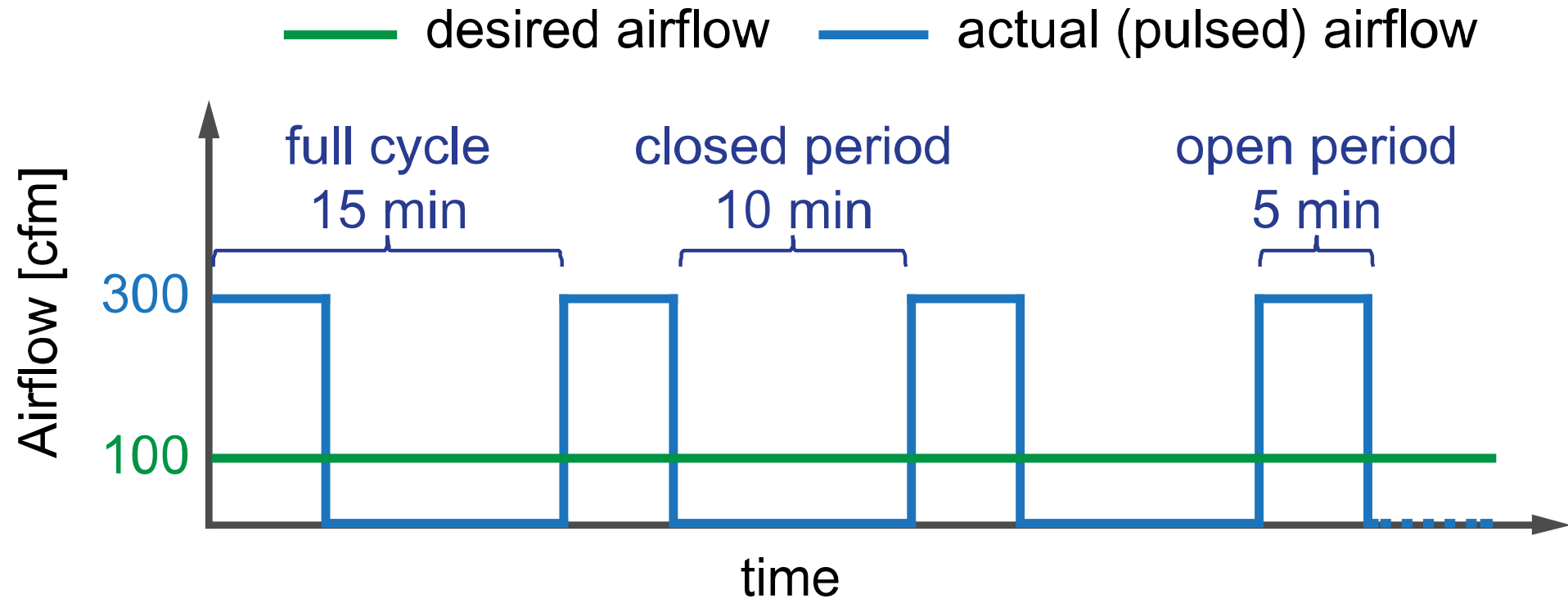

Will the occupants get enough outside air with TAV?

Total amount of outside air entering the building remains the same

TAV reduces the total amount of mixed air circulating in the building

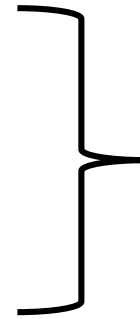

TAV increases the proportion of outside air supplied to the zones

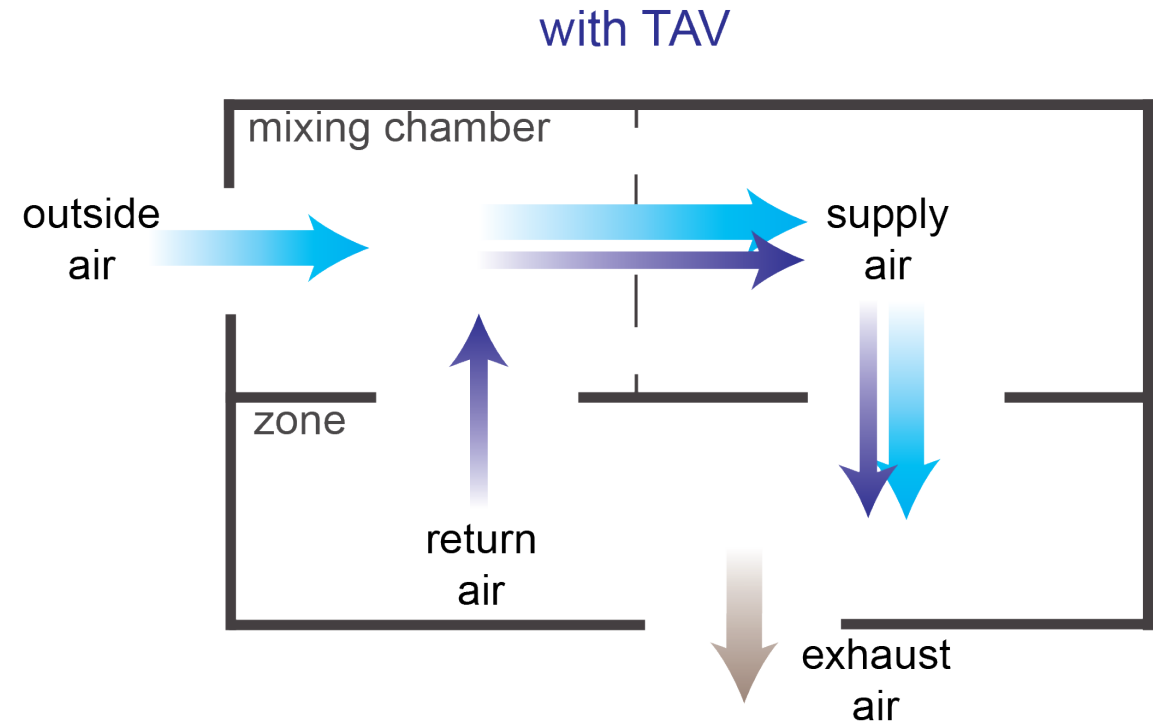
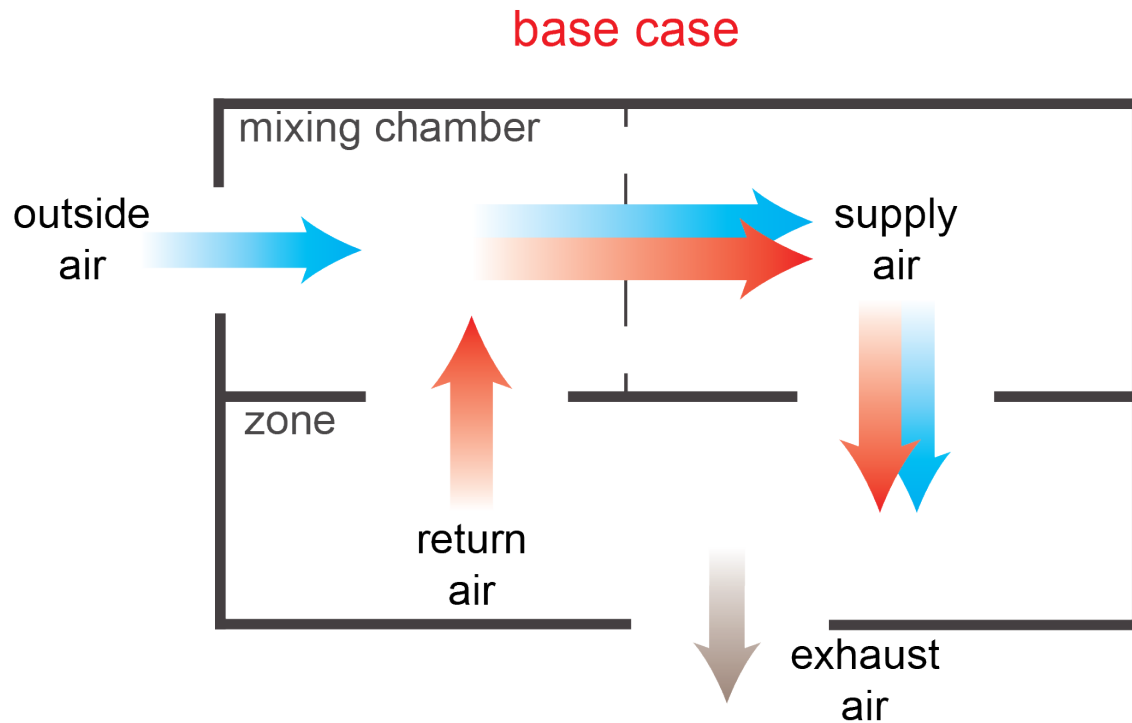

Field study in Sutardja Dai Hall

Building site:

- All-air VAV system
- Single-max controls
- TAV implemented in 109 zones out of 138

Schedule:

- April 2016
- **Baseline period: 10 weekdays**
- **Intervention period: 10 weekdays**
- Similar outside air temperature between baseline and intervention periods



Sutardja Dai Hall (SDH)
Source: Hathaway Dinwiddie

Field study in Sutardja Dai Hall

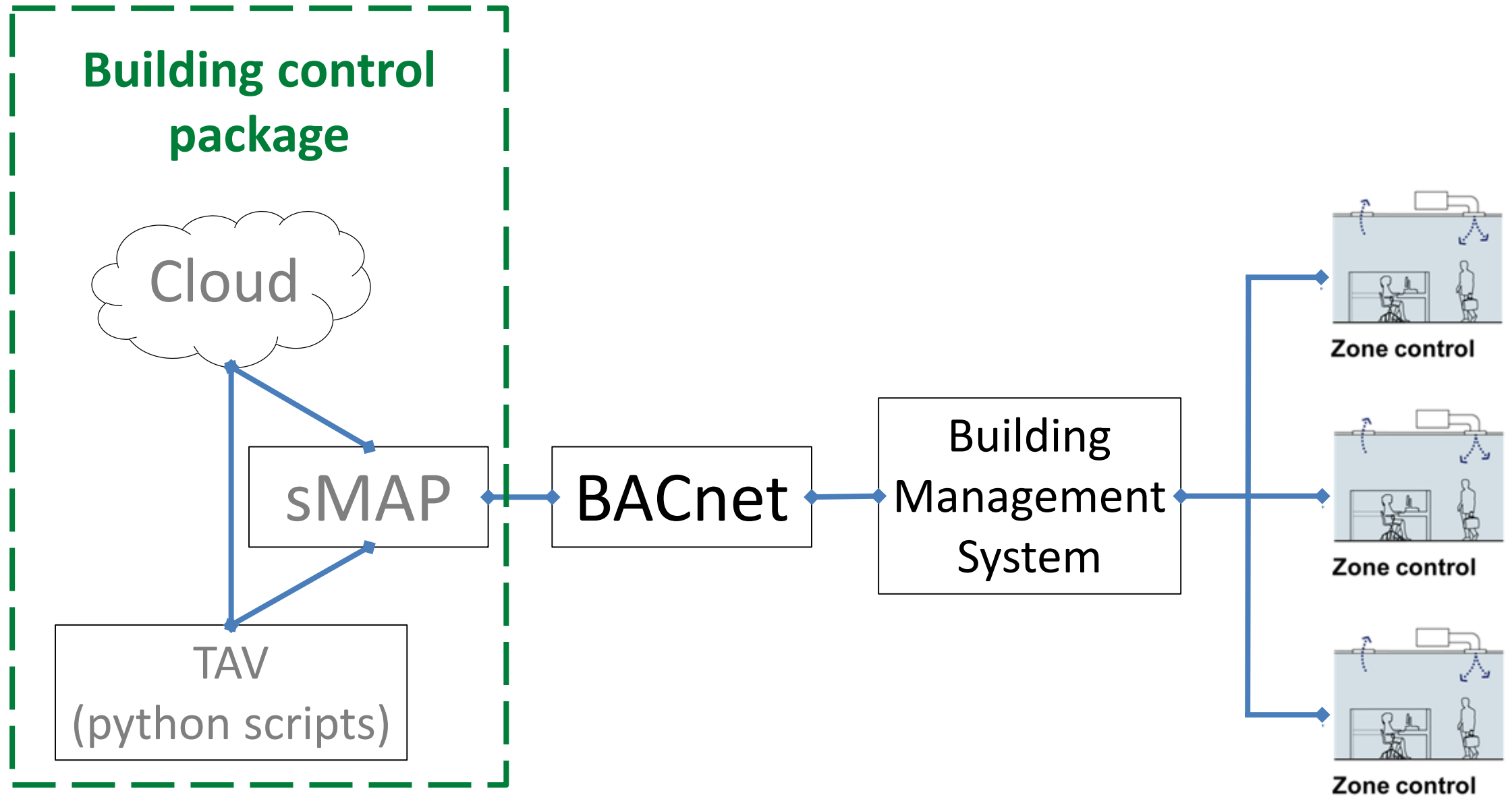

Results: Airflow

Zone ventilation rate

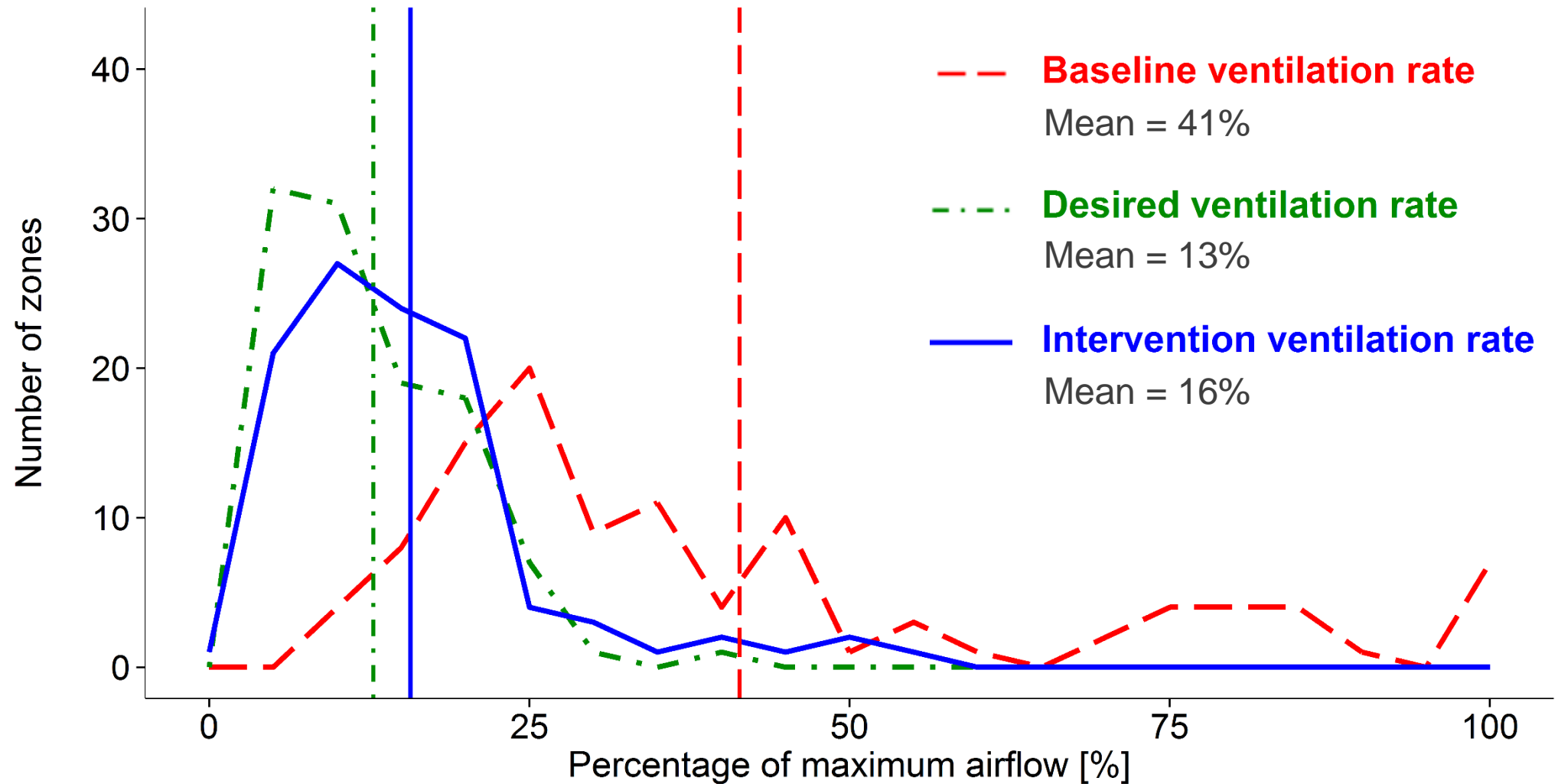

Results: Airflow (continued)

Zone airflow

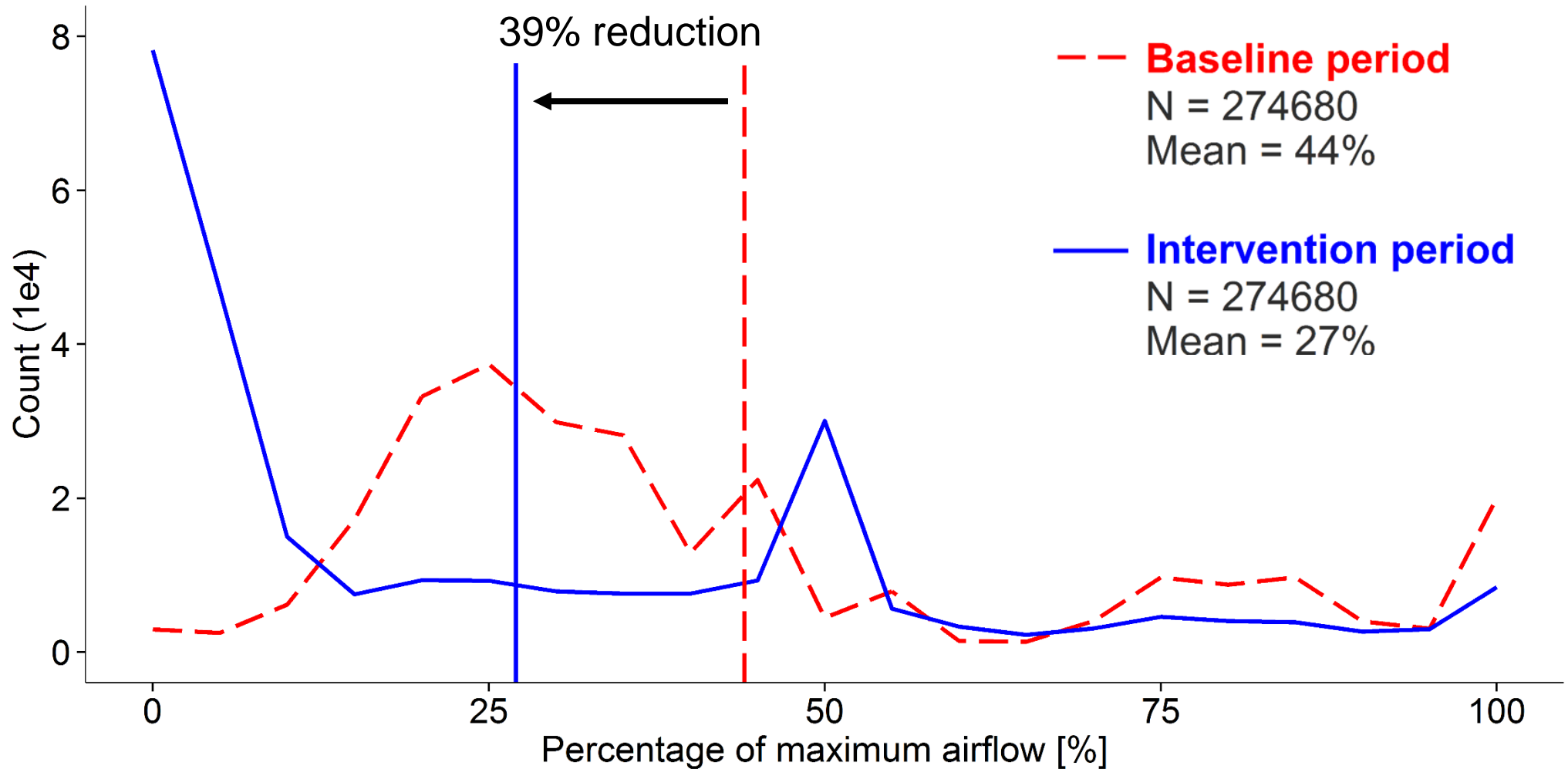

Results: Whole building airflow

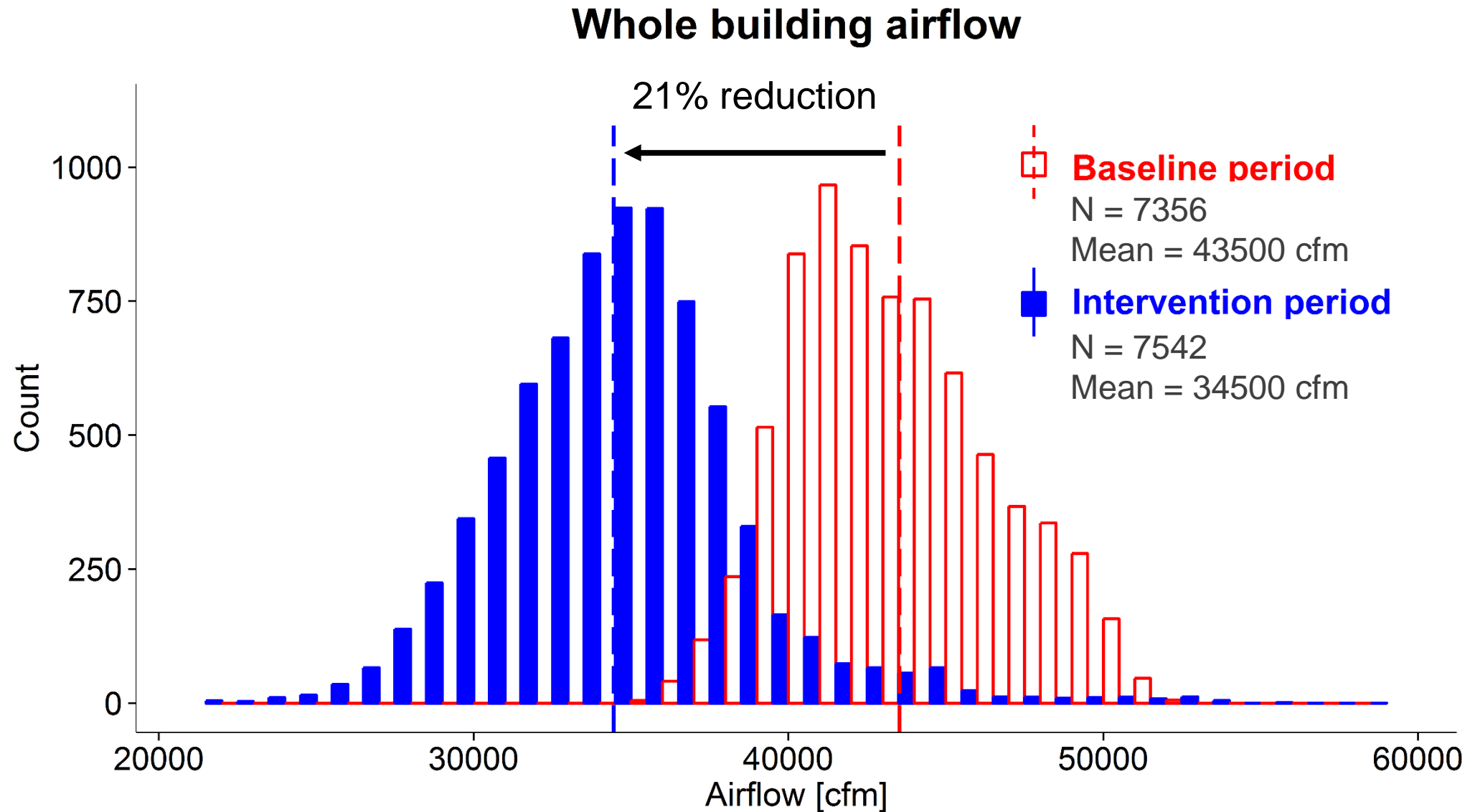

Results: Energy savings

- Power consumption during intervention period
- ▨ Savings compared to baseline period

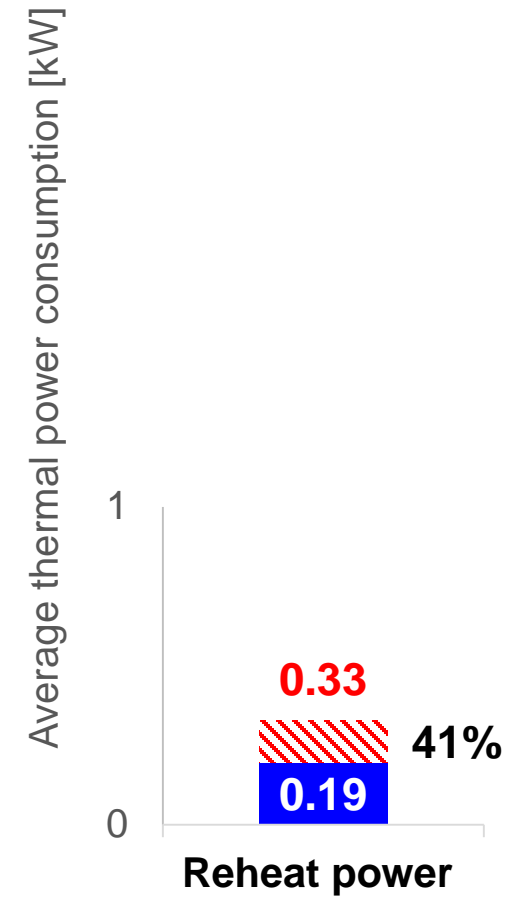
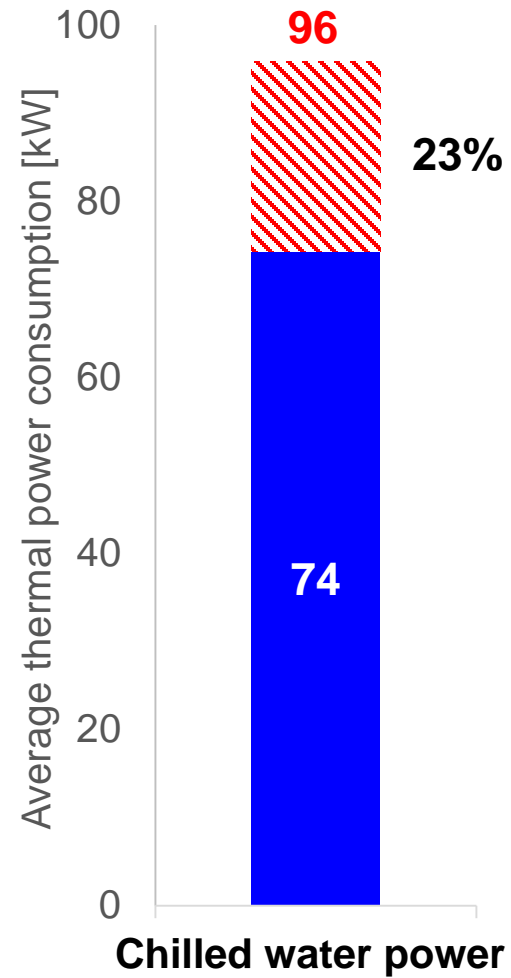
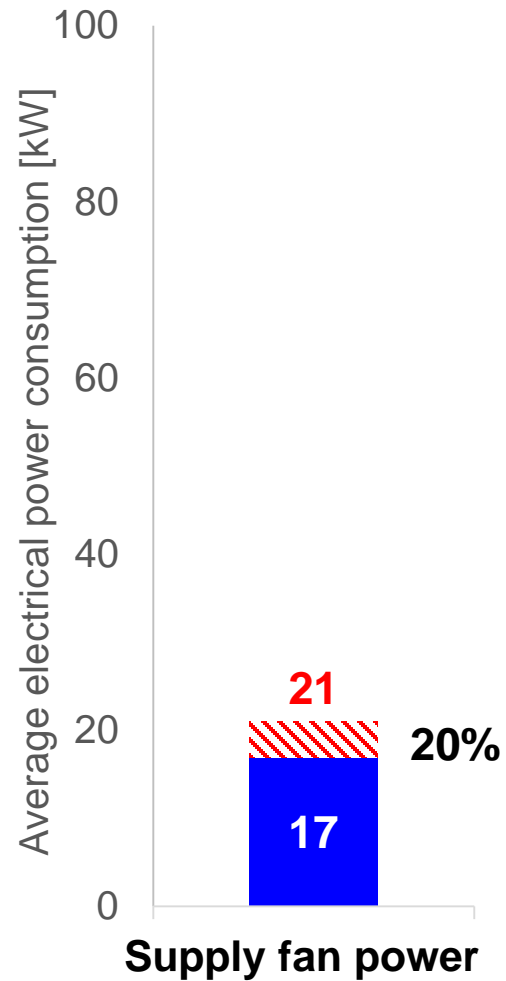

What about damper wear?

(a) Distance traveled by the dampers increased with TAV

(b) Number of dampers direction changes reduced with TAV

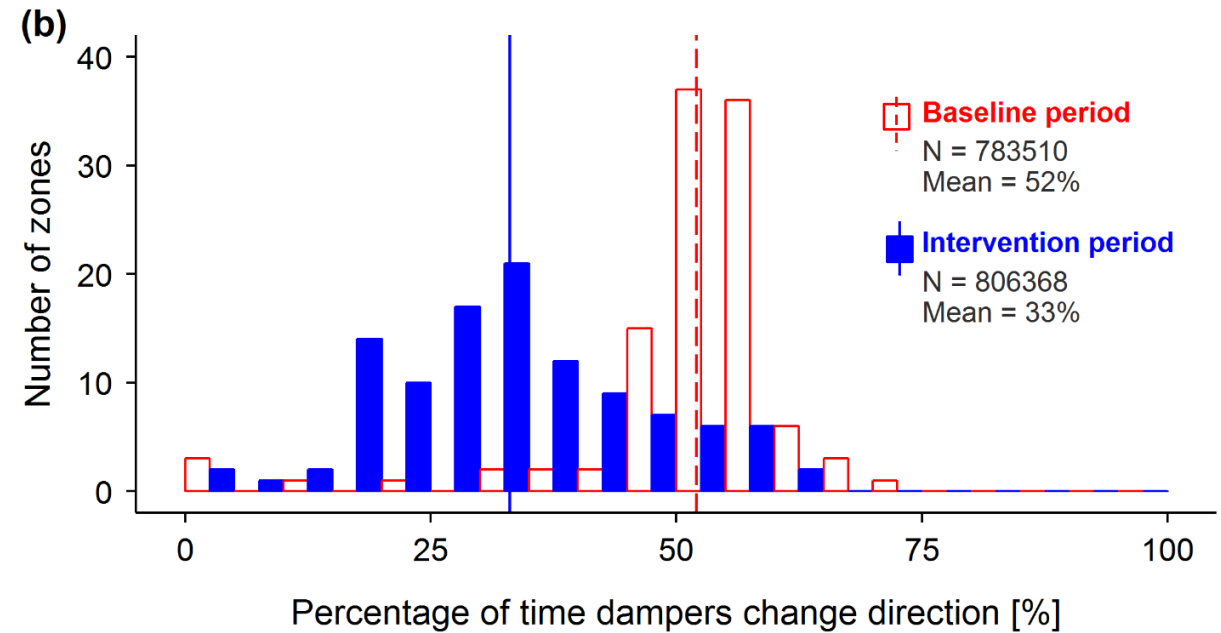
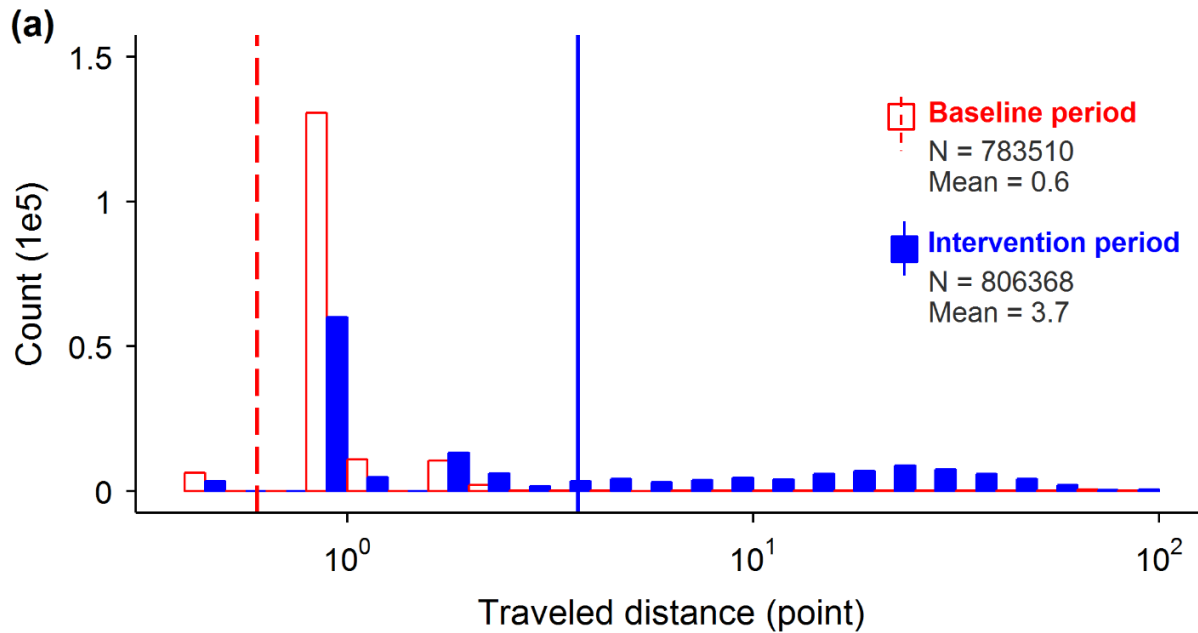

What about the sound when the damper moves?

- Tests in 28 zones following ASHRAE Performance Measurement Protocol guidelines
- Sound levels measurements within the PMP recommended range (35-45 dB(A))

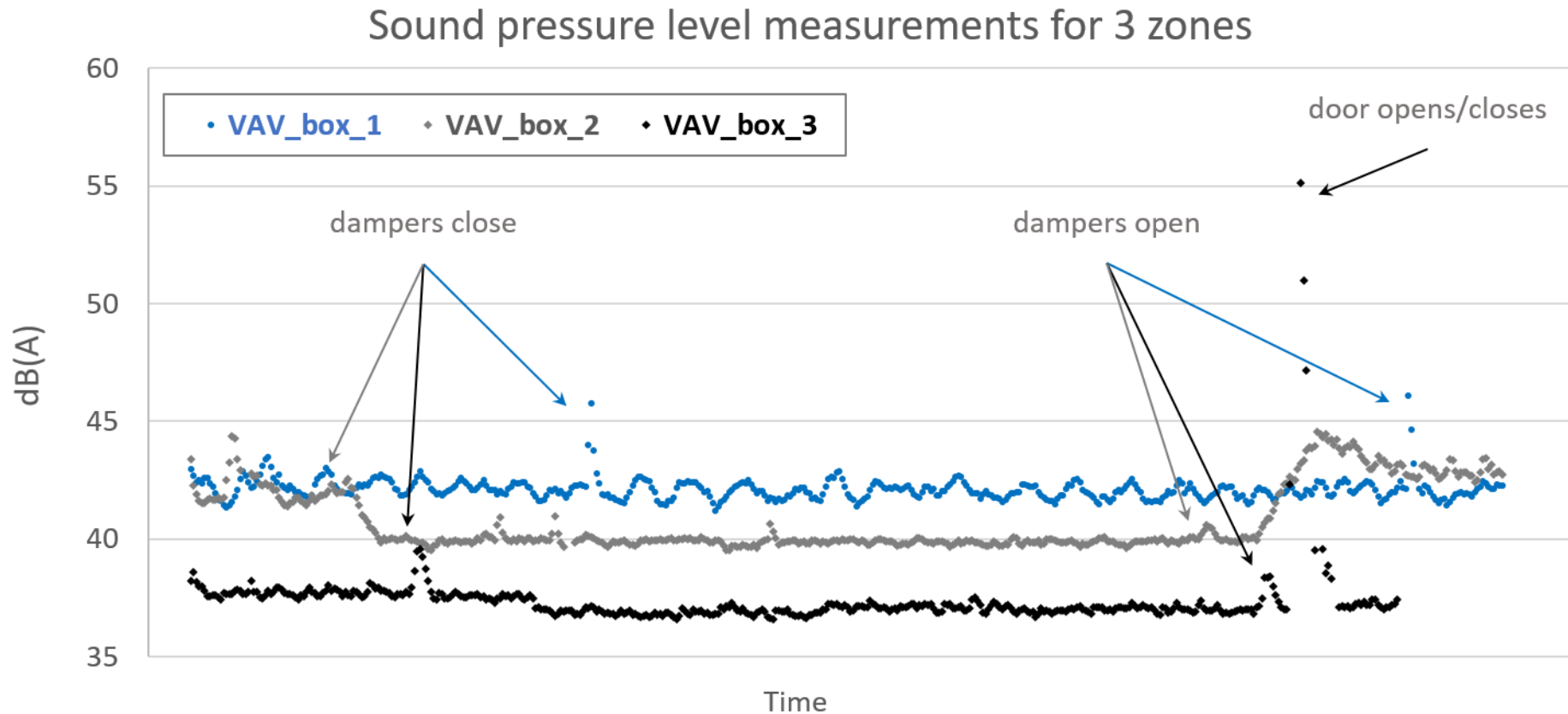

Conclusion

- TAV controls the average zone airflow to the minimum ventilation rate required by code
- TAV leverages the Internet of Things platform for buildings
- TAV has shown great potential for airflow and energy savings

TAV principle

